

Recognise and describe 3D shapes

- 1 Kim paints the faces of some 3D shapes.
She stamps the faces on to a sheet of paper.
Match the stamp to the 3D shape.

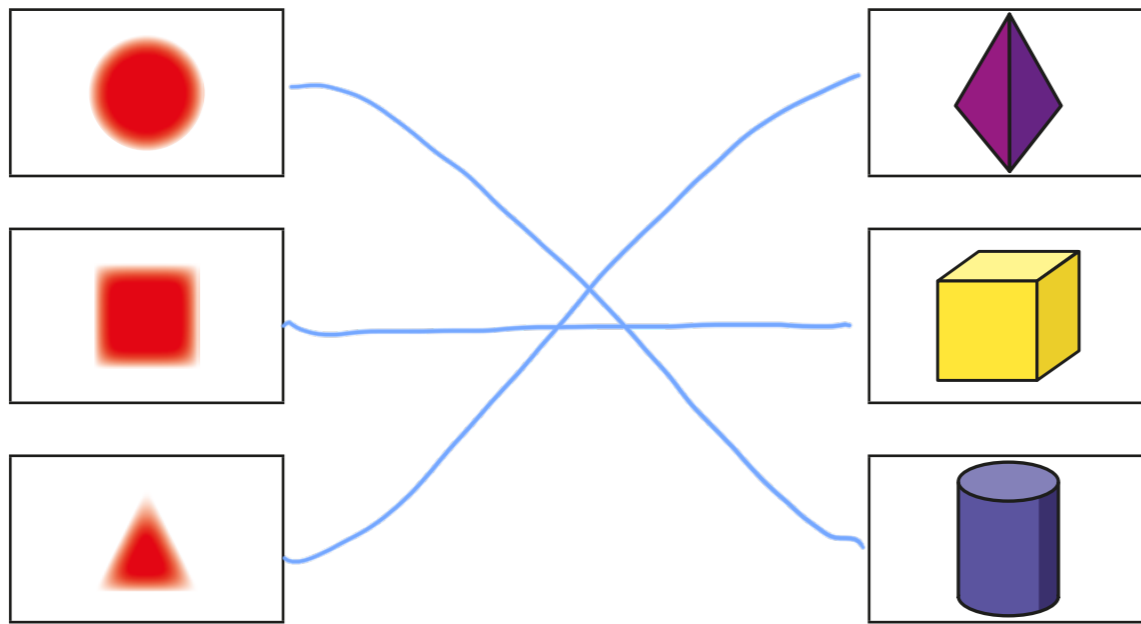

- 2 A cube is a special type of cuboid.

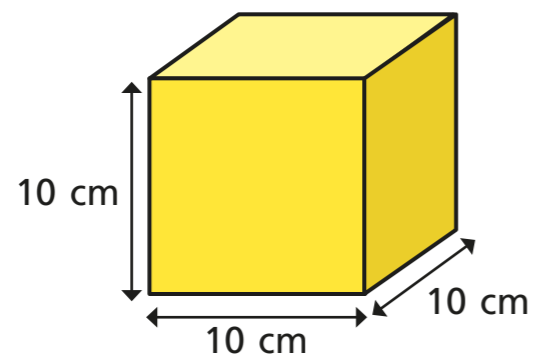

What is special about each face of a cube?
Talk about it with a partner.



- 3 Which of the shapes is a cube? Tick your answer.

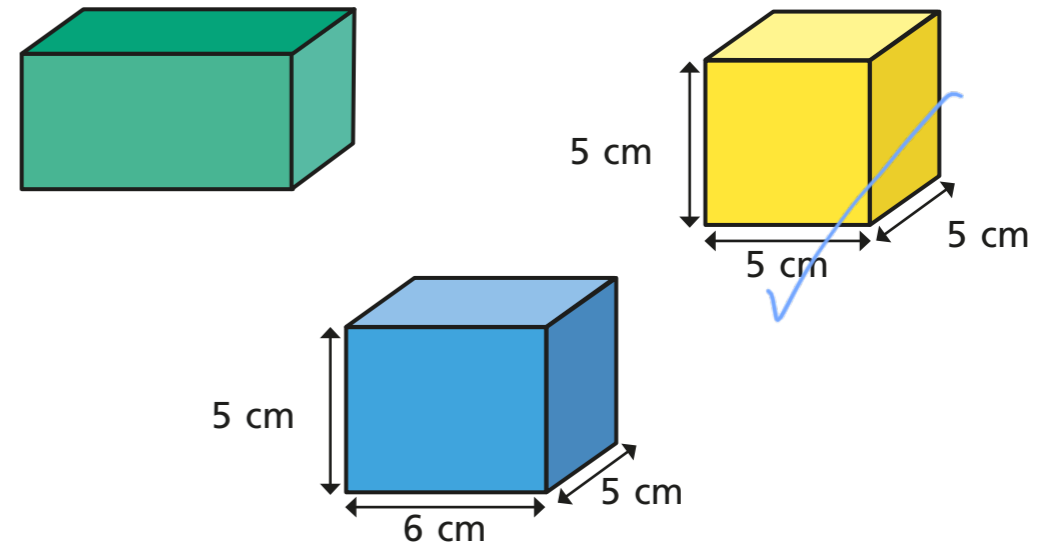

- 4 Here is a cuboid.

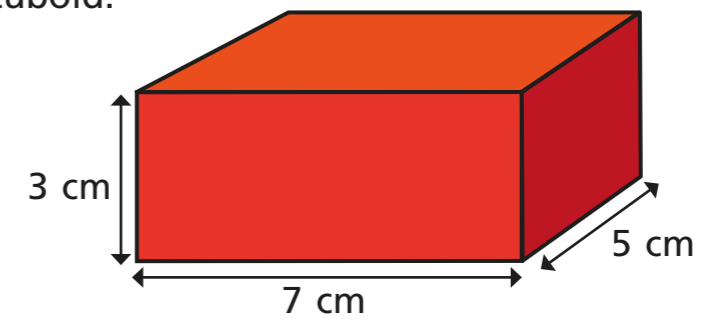

What do you notice about the opposite faces of a cuboid?

They are identical.

- 5 Match the 3D shapes to the labels.

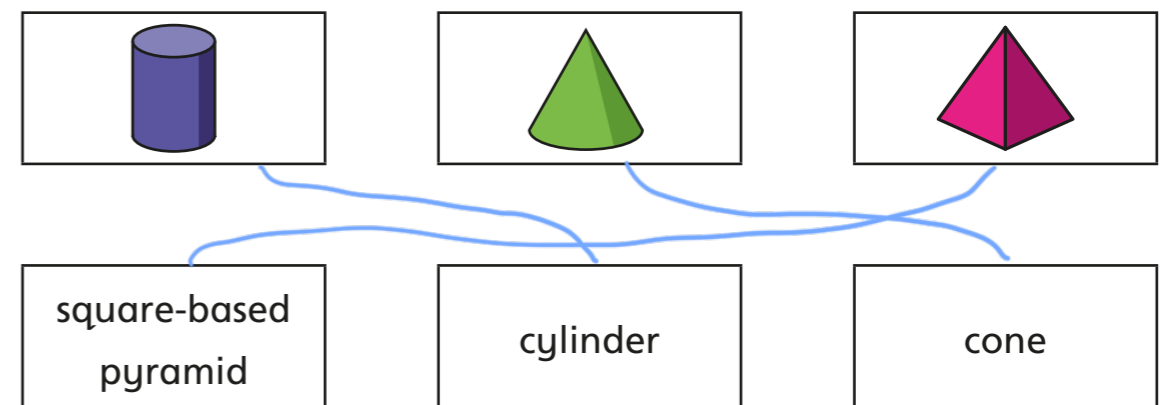



6 Here are some shapes.

a) Circle all the triangular prisms.

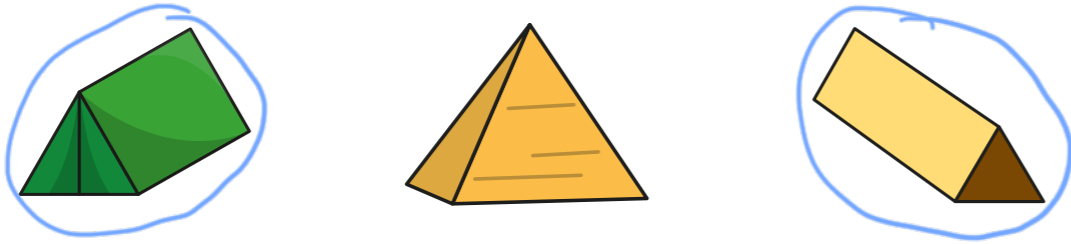

b) Circle all the spheres.

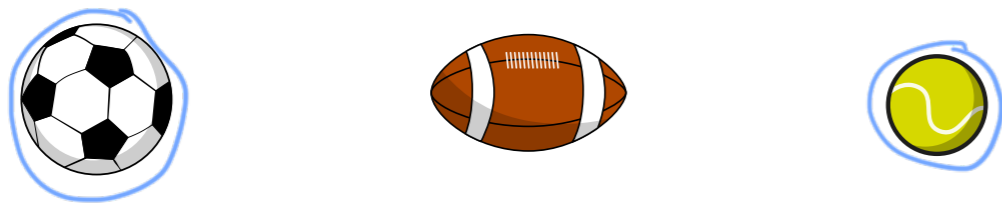

7 Complete the table.

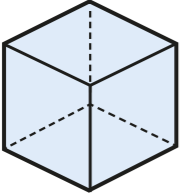
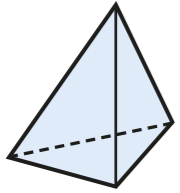
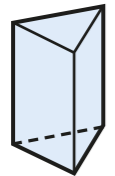
Shape	Number of edges	Number of faces	Number of vertices
	12	6	8
	6	4	4
	9	5	6

8 Here is a cuboid.

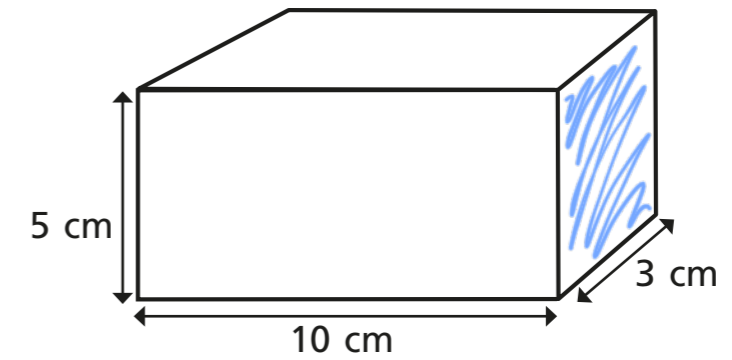

a) Shade a face that is a 5 cm by 3 cm rectangle.

b) What are the measurements of one of the other faces?

e.g. 10 cm by 5 cm

9 Huan sorts some shapes into prisms and non-prisms.

Prisms

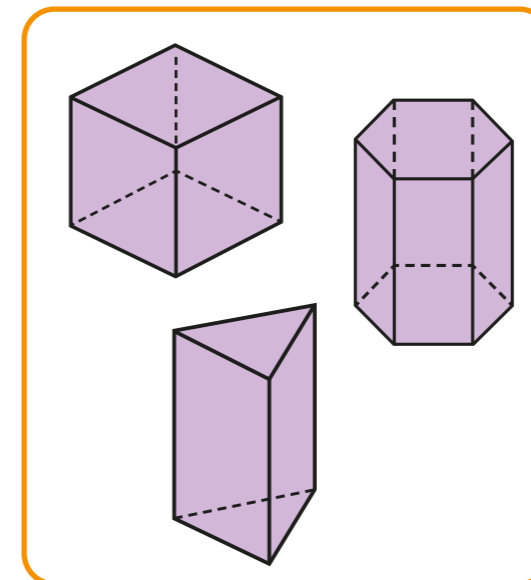

Non-prisms

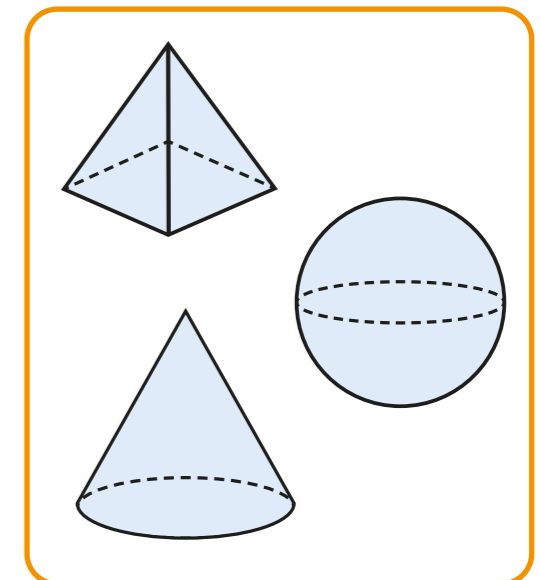

Talk to a partner about what a prism is like.

Can you find any prisms and non-prisms in your classroom?

